

DATA SHEET

○ Type.....	ASA 355Lb-2
○ Reference standard.....	IEC 60034-1 EN 60079-0 EN 60079-1 EN 60079-7
○ Rated output.....	315 kW
○ Rated stator voltage.....	400 V Δ
○ Stator current at 100% load at 400 V.....	542 A
○ Rated frequency.....	50 Hz
○ Number of poles.....	2
○ Rated speed.....	2980 rev/min
○ Efficiency at 100% load.....	95.2%
○ Power factor at 100% load.....	0.88
○ Rated duty.....	S1(continuous duty)
○ Break-down torque.....	2.9 x Mn
○ Locked rotor torque.....	2.3 x Mn
○ Locked rotor current.....	6.3 x In
○ Rotor inertia.....	4.09156 kgm ²
○ Insulation class.....	F
○ Direction of rotation.....	Both(CW&CCW)
○ Protection degree.....	IP55
○ Mounting.....	IM
○ Cooling method.....	IC 411
○ Ambient temperature.....	+40°C
○ Altitude.....	1000m
○ Bearing type.....	6319 drive end 6319 non drive end
○ Lubrication.....	regreasable bearings with UM 185 Li 3, Shell Alvania R3, SKF LGTH3 or similar
○ Relubricating interval	4200 [hrs] DE and NDE
○ Correcting interval.....	2000 [hrs] DE and NDE
○ Grease quantity	45g/bearing DE and NDE
○ Outline drawing.....	Page 2
○ Weight.....	1815 Kg
○ Vibration level :	A(acc.IEC 60034-14)
○ Noise level	acc.IEC 60034-9
○ Cable entries.....	2xM63x1.5
○ Minimum and maximum admissible supply cable diameter.....	29-44mm
○ Climate execution	N

**The overall and mounting dimensions
IM 1001**

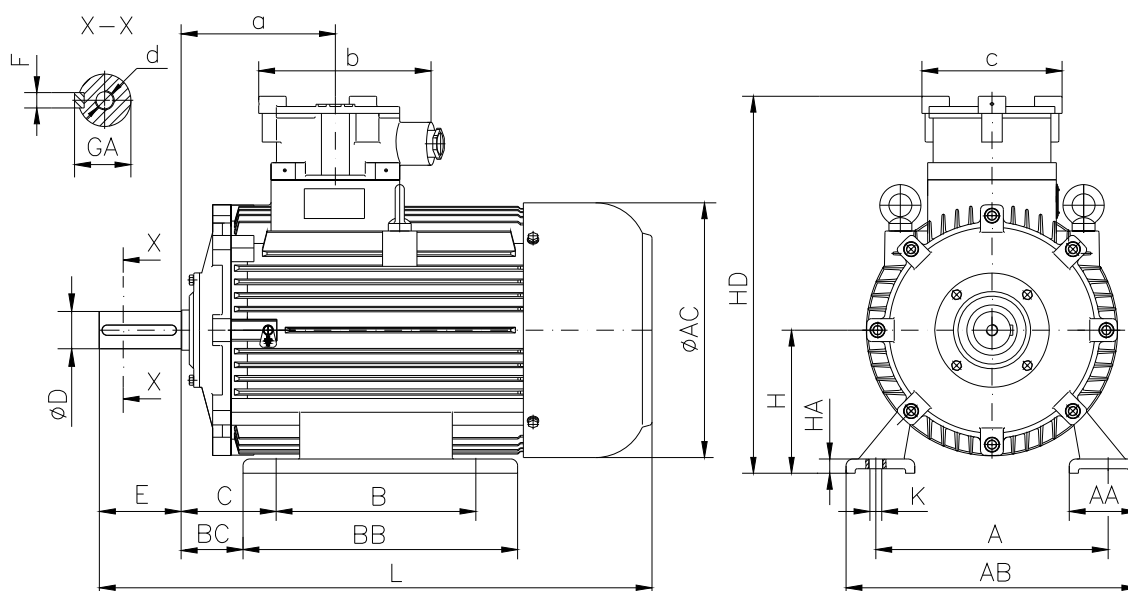

Frame size	Dimensions (mm)																				
	Foot mounting										Shaft extension					HD	AC	L	a	b	c
355 Lb-2	A	B	C	H _{0.5}	K	AA	AB	BB	BC	HA	D	E	F	GA	d						
	610	630	254	355	28	110	714	695	177	32	70m6	140	20	74.5	M20	960	705	1460	320	460	355

**The overall and mounting dimensions
IM 3001; IM 3011**

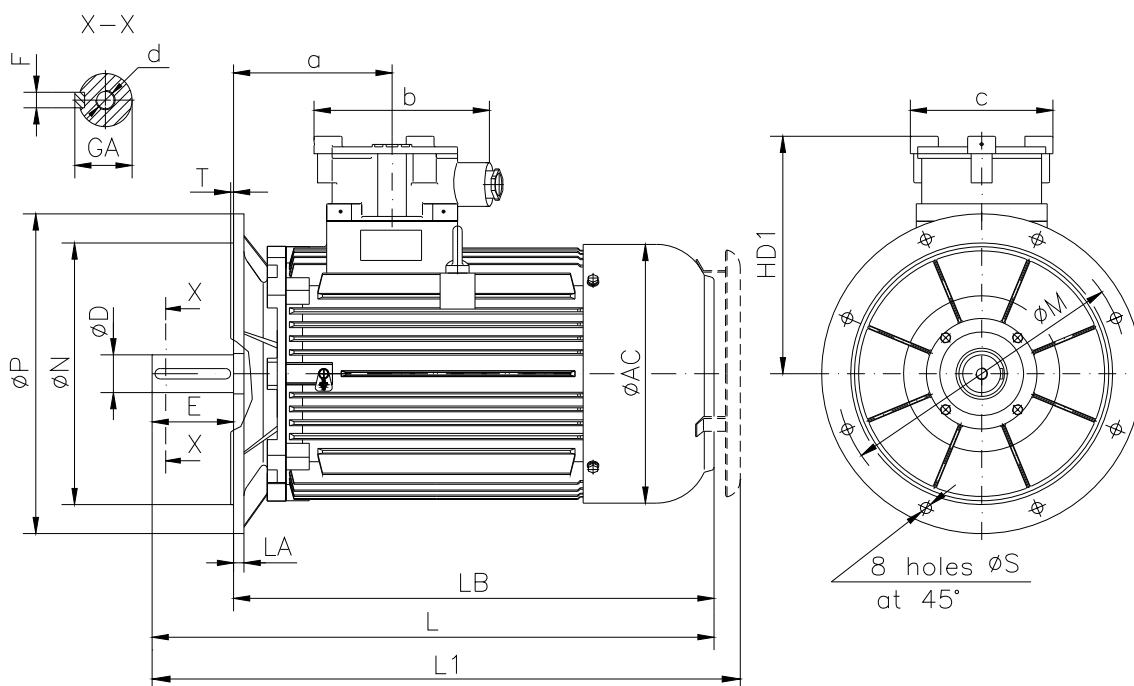

Frame size	Dimensions (mm)																		
	Flange mounting (B5)					Shaft extension					HD1	AC	LA	LB	L	L1	a	b	c
	N	M	P	S	T	D	E	F	GA	d									
355 Lb-2	680j6	740	800	24	6	70m6	140	20h9	74.5	M20	605	705	35	1310	1460	1560	320	460	355

**The overall and mounting dimensions
IM 2001**

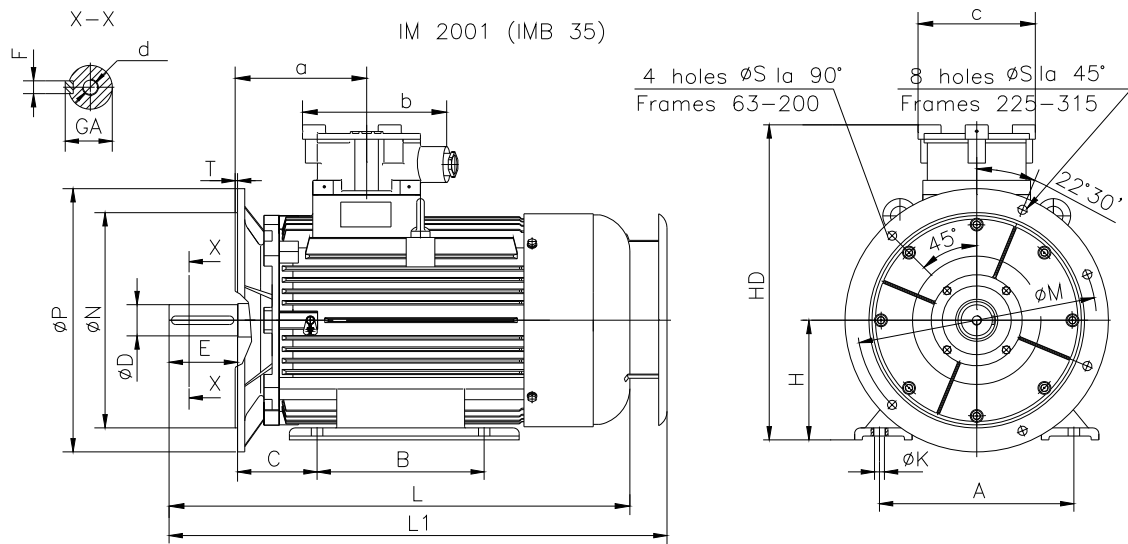

Frame size	Dimensions (mm)																				
	Foot mounting					Flange mounting					Shaft extension					HD	L	L1	a	b	c
355 Lb-2	A	B	C	H _{0.5}	K	N	M	P	S	T	D	E	F	GA	d						
	610	630	254	355	28	680j6	740	800	24	6	70m6	140	20h9	74.5	M20	960	1460	1560	320	460	355