

**DATA SHEET**

○ Type.....	ASA 250M-8
○ Reference standard.....	IEC 60034-1 EN 60079-0 EN 60079-1 EN 60079-7
○ Rated output.....	30 kW
○ Rated stator voltage.....	400 V
○ Rated frequency.....	50 Hz
○ Stator current at 100% load at 400 V.....	58.7 A
○ Number of poles.....	8
○ Rated speed.....	732 rev/min
○ Efficiency at 100% load.....	91%
○ Power factor at 100% load.....	0.81
○ Break-down torque.....	2.3 x Mn
○ Locked rotor torque.....	2.2 x Mn
○ Locked rotor current.....	6.5 x In
○ Rotor inertia.....	0.689 kgm <sup>2</sup>
○ Insulation class.....	F
○ Direction of rotation.....	Both(CW&CCW)
○ Protection degree.....	≥IP55
○ Mounting.....	IM
○ Cooling method.....	IC 411
○ Max. ambient temperature.....	+40°C
○ Altitude.....	1000m
○ Bearing type.....	6314 2Z drive end 6313 2Z non drive end
○ Weight.....	465 Kg
○ Thermal winding protection.....	3xPTC
○ Outline drawing.....	Page 2
○ Vibration level :.....	A(acc.IEC 60034-14)
○ Noise level.....	acc.IEC 60034-9
○ Cable entries.....	2xM50x1.5
○ Additional cable entries.....	1xM20x1.5
○ Climate execution.....	N

**The overall and mounting dimensions  
IM 1001**

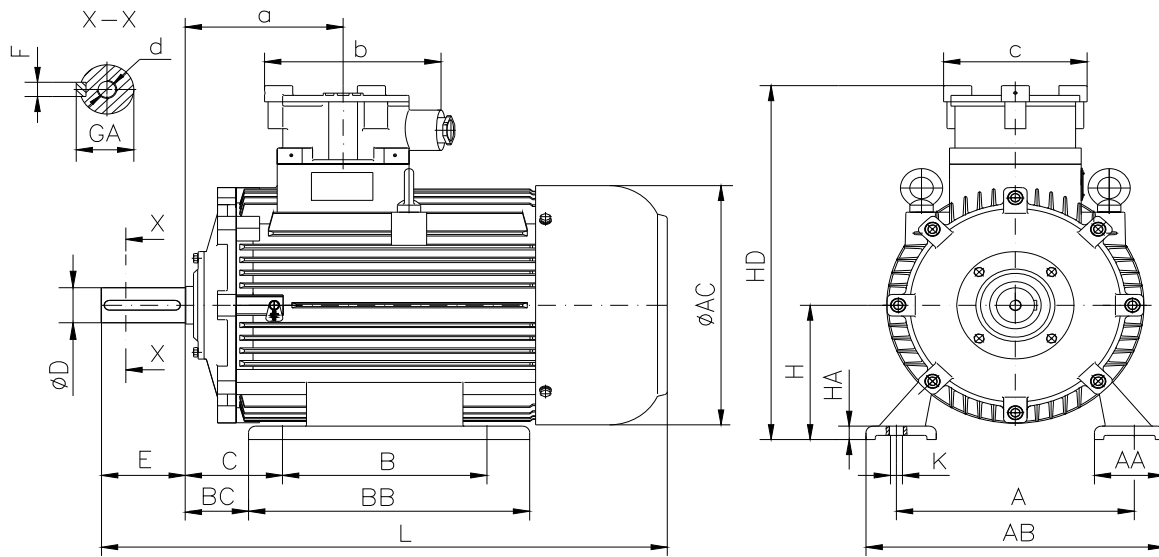

Frame size	Dimensions (mm)																				
	Foot mounting										Shaft extension						HD	AC	L	a	b
250 M-8	A	B	C	$H_{L0.5}$	K	AA	AB	BB	BC	HA	D	E	F	GA	d						
	406	349	168	250	24	120	510	480	114	20	65m6	140	18h9	69	M20	660	446	970	275	275	240

**The overall and mounting dimensions  
IM 3001; IM 3011**

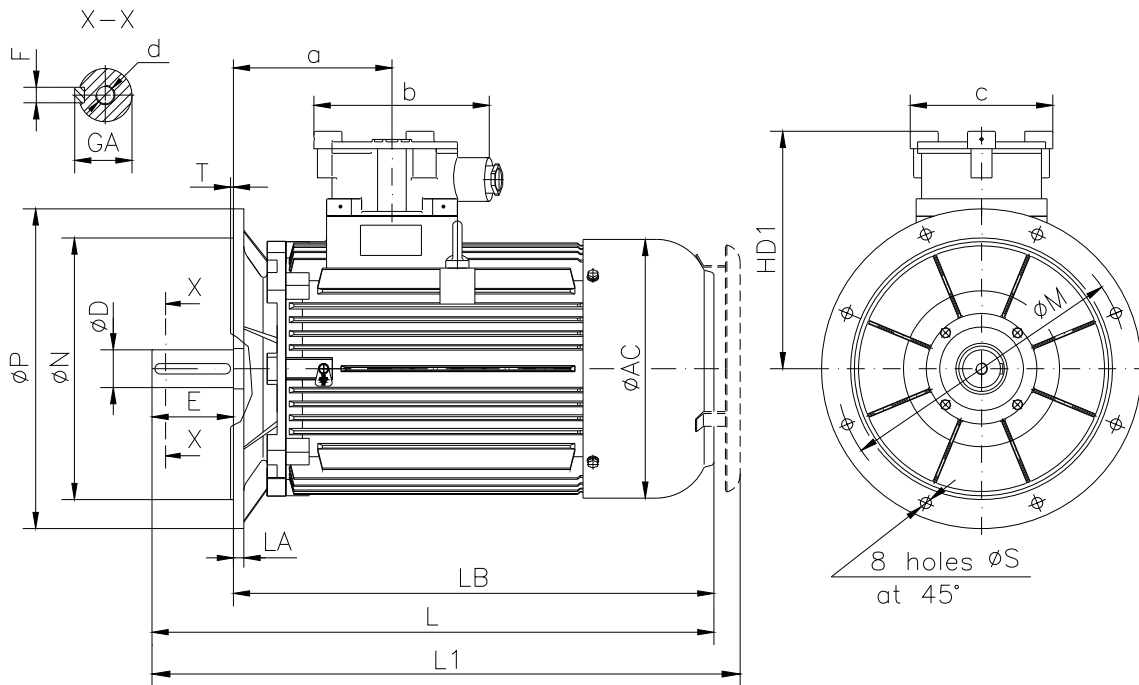

Frame size	Dimensions (mm)																		
	Flange mounting (B5)					Shaft extension					HD1	AC	LA	LB	L	L1	a	b	c
N	M	P	S	T	D	E	F	GA	d										
250 M-8	450j6	500	550	18.5	5	65m6	140	18h9	69	M20	410	446	18	825	970	1015	275	275	240

**The overall and mounting dimensions  
IM 2001**

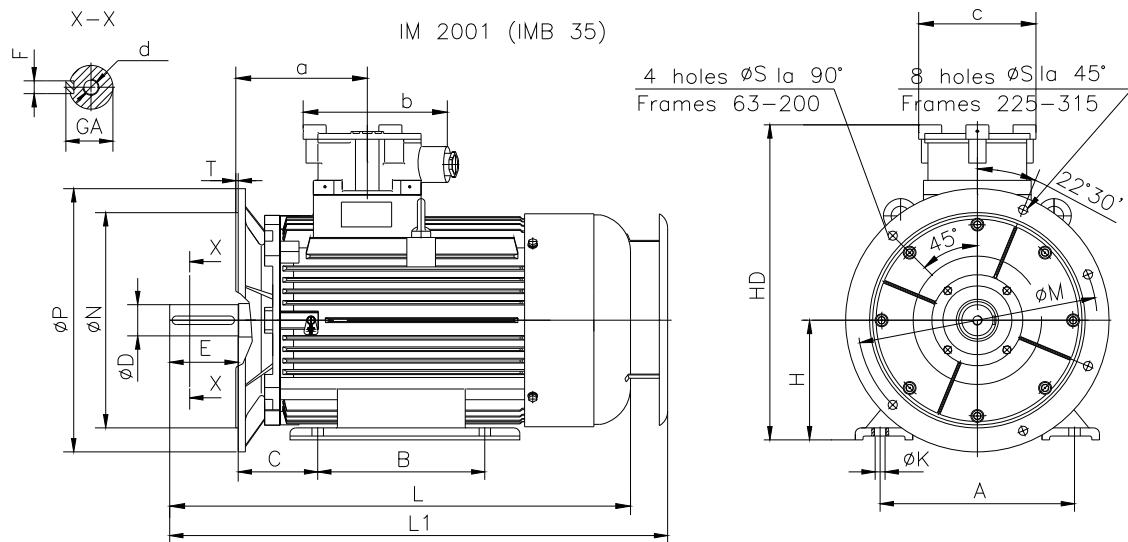

Frame size	Dimensions (mm)																				
	Foot mounting					Flange mounting					Shaft extension					HD	L	L1	a	b	c
250 M-8	A	B	C	H <sub>0.5</sub>	K	N	M	P	S	T	D	E	F	GA	d						
	406	349	168	250	24	450j6	500	550	18.5	5	65m6	140	18h9	69	M20	660	970	1015	275	275	240