

DATA SHEET

○ Type.....	ASA 225M-4
○ Reference standard.....	IEC 60034-1 EN 60079-0 EN 60079-1 EN 60079-7
○ Rated output.....	45 kW
○ Rated stator voltage.....	400 V
○ Rated frequency.....	50 Hz
○ Stator current at 100% load.....	79.4 A
○ Number of poles.....	4
○ Rated speed.....	1477 rev/min
○ Efficiency at 100% load.....	93%
○ Power factor at 100% load.....	0.88
○ Break-down torque.....	2.4 x Mn
○ Locked rotor torque.....	2 x Mn
○ Locked rotor current.....	7.4 x In
○ Rotor inertia.....	0.456 kgm ²
○ Insulation class.....	F
○ Direction of rotation.....	Both(CW&CCW)
○ Protection degree.....	≥IP55
○ Mounting.....	IM
○ Cooling method.....	IC 411
○ Max. ambient temperature.....	+40°C
○ Altitude.....	1000m
○ Bearing type.....	6313 2Z drive end 6313 2Z non drive end
○ Weight.....	406 Kg
○ Outline drawing.....	Page 2
○ Thermal winding protection.....	3xPTC
○ Vibration level :.....	A(acc.IEC 60034-14)
○ Noise level	acc.IEC 60034-9
○ Cable entries.....	2xM50x1.5
○ Additional cable entries.....	1xM20x1.5
○ Climate execution	N

**The overall and mounting dimensions
IM 1001**

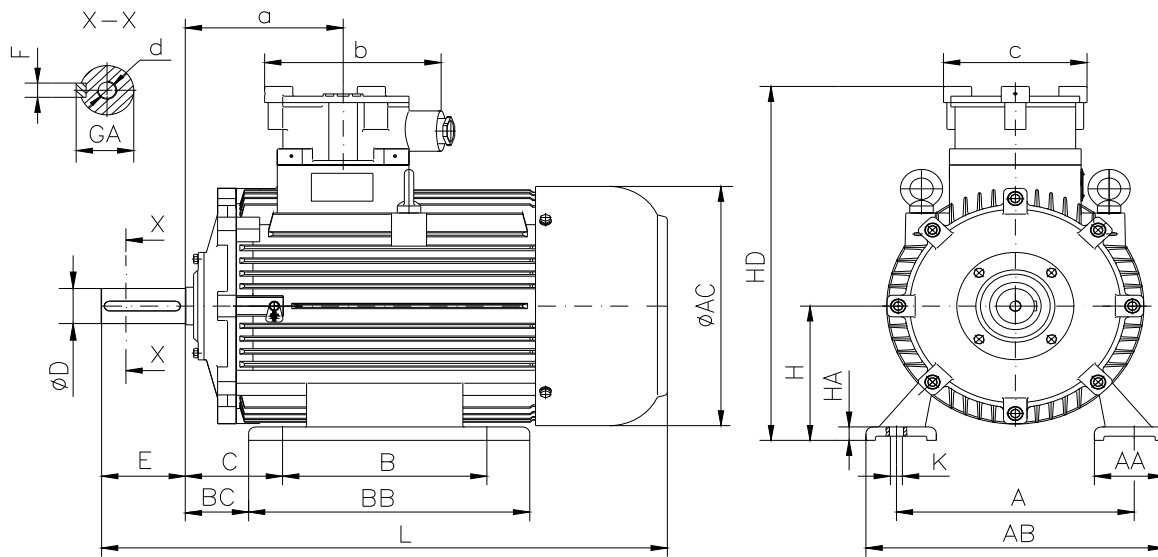

Frame size	Dimensions (mm)																				
	Foot mounting										Shaft extension						HD	AC	L	a	b
225 M-4	A	B	C	H _{0,5}	K	AA	AB	BB	BC	HA	D	E	F	GA	d						
	356	311	149	225	18.5	100	440	430	114	20	60m6	140	18h9	64	M20	635	446	920	275	275	240

**The overall and mounting dimensions
IM 3001; IM 3011**

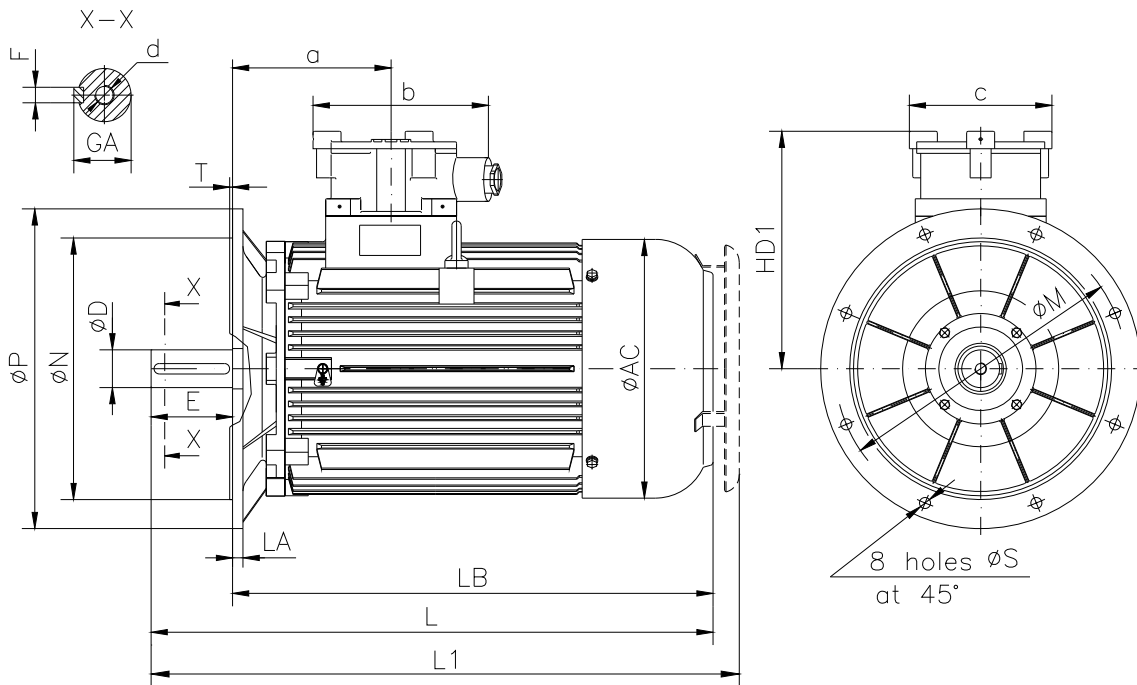

Frame size	Dimensions (mm)											HD1	AC	LA	LB	L	L1	a	b	c
	Flange mounting (B5)					Shaft extension														
	N	M	P	S	T	D	E	F	GA	d										
225 M-4	350j6	400	450	18.5	5	60m6	140	18h9	64	M20	410	446	18	775	920	965	275	275	240	

**The overall and mounting dimensions
IM 2001**

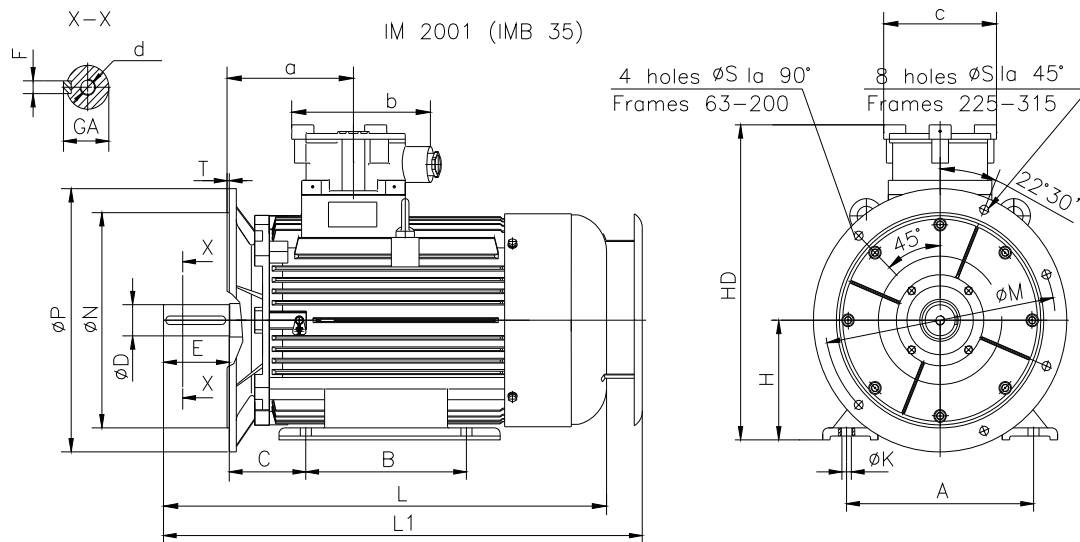

Frame size	Dimensions (mm)																				
	Foot mounting					Flange mounting					Shaft extension					HD	L	L1	a	b	c
225 M-4	A	B	C	H _{0.5}	K	N	M	P	S	T	D	E	F	GA	d						
	356	311	149	225	18.5	350j6	400	450	18.5	5	60m6	140	18h9	64	M20	635	915	965	275	275	240