

DATA SHEET

○ Type.....	ASA 200Lb-2
○ Reference standard.....	IEC 60034-1 EN 60079-0 EN 60079-1 EN 60079-7
○ Rated output.....	37 kW
○ Rated stator voltage.....	400 V
○ Rated frequency.....	50 Hz
○ Stator current at 100% load.....	64.4 A
○ Number of poles.....	2
○ Rated speed.....	2943 rev/min
○ Efficiency at 100% load.....	92.2%
○ Power factor at 100% load.....	0.9
○ Break-down torque.....	2.8 x Mn
○ Locked rotor torque.....	2.2 x Mn
○ Locked rotor current.....	6.7 x In
○ Rotor inertia.....	0.169519 kgm ²
○ Insulation class.....	F
○ Direction of rotation.....	Both(CW&CCW)
○ Protection degree.....	≥IP55
○ Mounting.....	IM
○ Cooling method.....	IC 411
○ Max. ambient temperature.....	+40°C
○ Altitude.....	1000m
○ Bearing type.....	6312 2Z drive end 6312 2Z non drive end
○ Weight.....	300 Kg
○ Outline drawing.....	Page 2
○ Thermal winding protection.....	3xPTC
○ Vibration level :.....	A(acc.IEC 60034-14)
○ Noise level	acc.IEC 60034-9
○ Cable entries.....	2xM50x1.5
○ Additional cable entries.....	1xM20x1.5
○ Climate execution	N

**The overall and mounting dimensions
IM 1001**

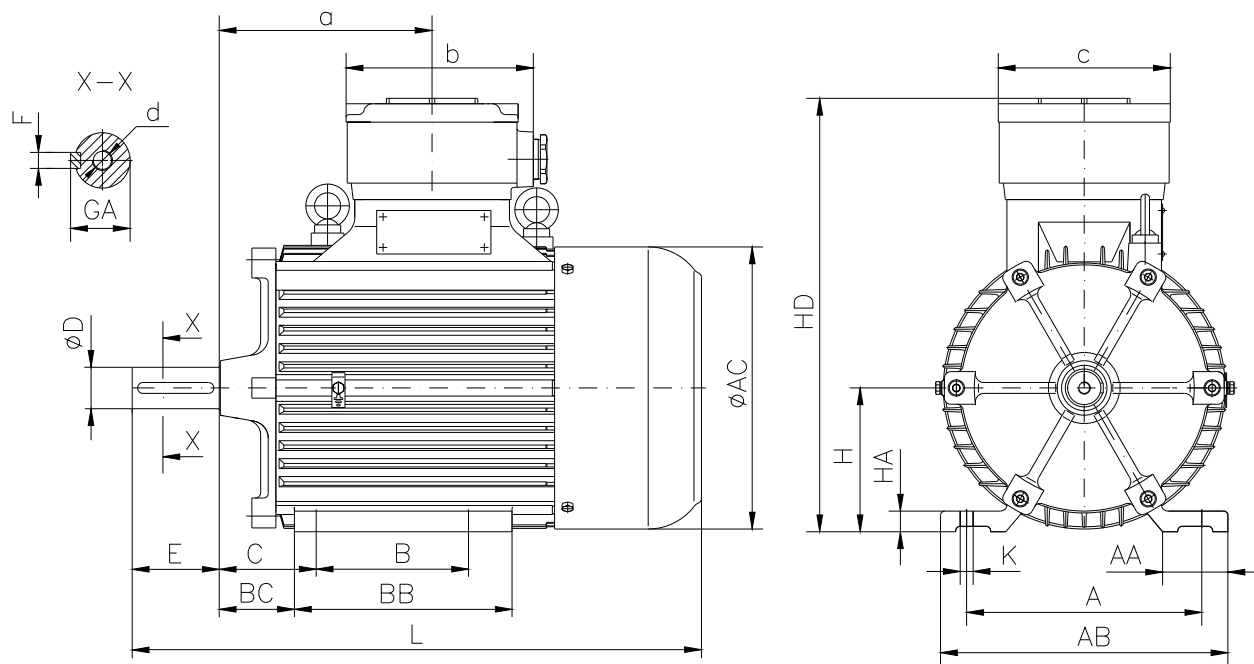

Frame size	Dimensions (mm)																				
	Foot mounting										Shaft extension					HD	AC	L	a	b	c
200 Lb-2	A	B	C	H _{0.5}	K	AA	AB	BB	BC	HA	D	E	F	GA	d						
	318	305	133	200	18.5	82	400	380	95	25	55m6	110	16h9	59	M20	580	396	805	310	275	240

**The overall and mounting dimensions
IM 3001; IM 3011**

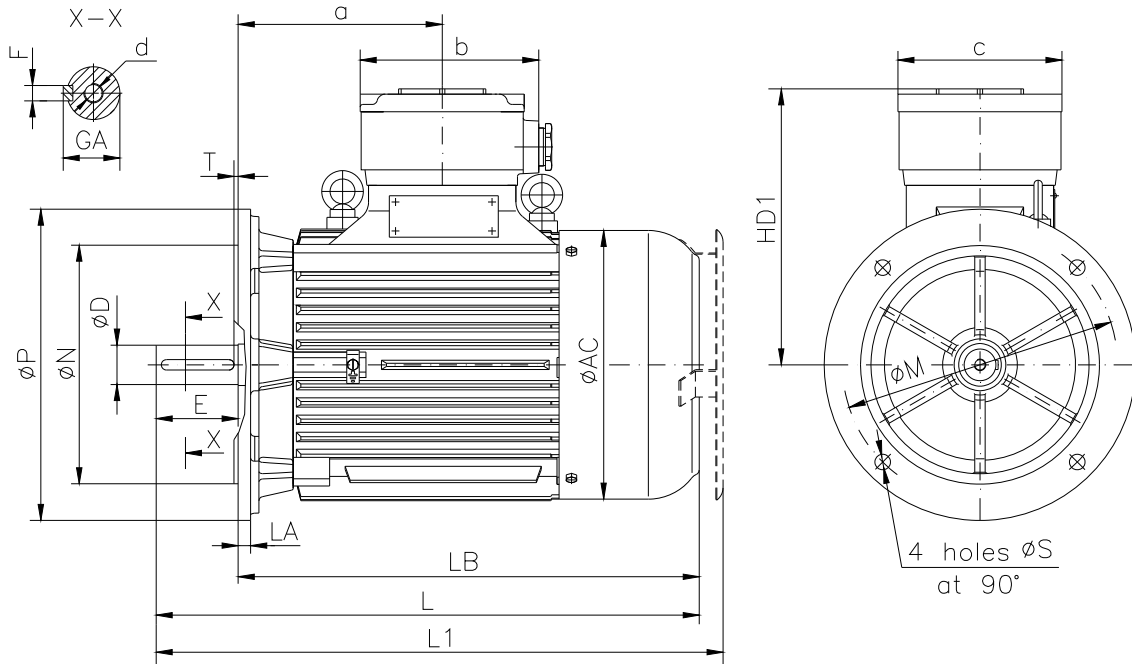

Frame size	Dimensions (mm)											HD1	AC	LA	LB	L	L1	a	b	c
	Flange mounting (B5)					Shaft extension														
200 Lb-2	N	M	P	S	T	D	E	F	GA	d										
	300j6	350	400	18.5	5	55m6	110	16h9	59	M20	383	396	16	693	805	849	310	275	240	

**The overall and mounting dimensions
IM 2001**

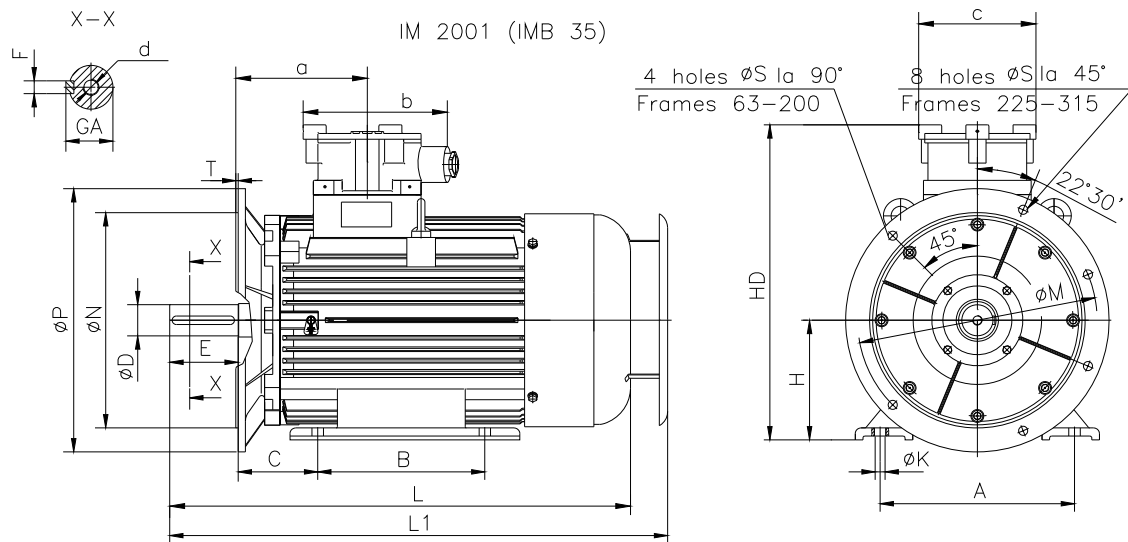

Frame size	Dimensions (mm)																				
	Foot mounting					Flange mounting					Shaft extension					HD	L	L1	a	b	c
200 Lb-2	A	B	C	H _{0.5}	K	N	M	P	S	T	D	E	F	GA	d						
	318	305	133	200	18.5	300j6	350	400	18.5	5	55m6	110	16h9	59	M20	580	805	849	310	275	240