

DATA SHEET

| | |
|--|---|
| ○ Type..... | E2-ASA 80a-2 |
| ○ Reference standard..... | IEC 60034-1; 60034-30 EN 60079-0 EN 60079-1 EN 60079-7 |
| ○ Rated output..... | 0.75 kW |
| ○ Rated stator voltage..... | 400V |
| ○ Stator current at 100% load..... | 1.59 [A] |
| ○ Number of poles..... | 2 |
| ○ Rated speed..... | 2865 rev/min |
| ○ Rated frequency..... | 50 Hz |
| ○ Efficiency at 100%, 75%, 50% load..... | 80.3%, 79.5%, 76.1% |
| ○ Power factor at 100% load..... | 0.85 |
| ○ Break-down torque..... | 4.3 x Mn |
| ○ Locked rotor torque..... | 4.1 x Mn |
| ○ Locked rotor current..... | 6.3 x In |
| ○ Rotor inertia..... | 0.001251 kgm ² |
| ○ Insulation class..... | F |
| ○ Direction of rotation..... | Both(CW&CCW) |
| ○ Protection degree..... | ≥IP55 |
| ○ Mounting..... | IM |
| ○ Cooling method..... | IC 411 |
| ○ Max. ambient temperature..... | +40°C |
| ○ Altitude..... | 1000m |
| ○ Bearing type..... | 6304 2Z drive end 6304 2Z non drive end |
| ○ Weight..... | 22 Kg |
| ○ Outline drawing..... | Page 2 |
| ○ Vibration level :..... | A (acc.IEC 60034-14) |
| ○ Noise level | acc.IEC 60034-9 |
| ○ Cable entries..... | 1xM25x1.5 |
| ○ Climate execution | N |

**The overall and mounting dimensions
IM 1001**

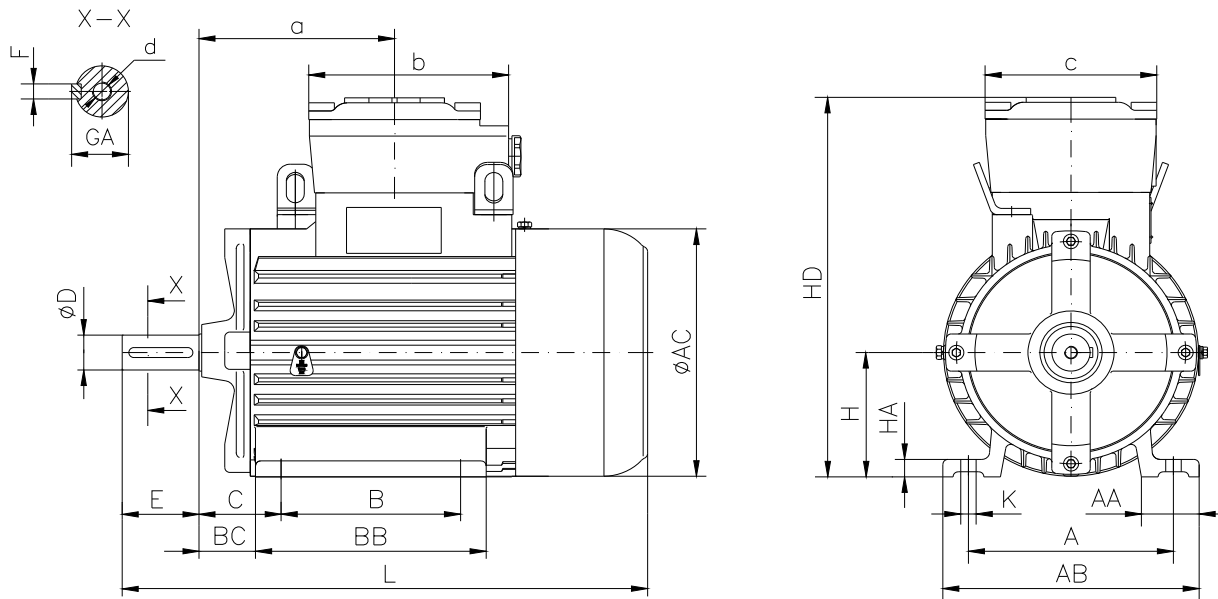

| Frame size | Dimensions (mm) | | | | | | | | | | | | | | | | | | | | |
|------------|-----------------|-----|------------------|----|----|----|-----|-----|------|----|-----------------|----|-----|------|----|-----|-----|-----|-----|-----|-----|
| | Foot mounting | | | | | | | | | | Shaft extension | | | | | HD | AC | L | a | b | c |
| A | B | C | H _{0.5} | K | AA | AB | BB | BC | HA | D | E | F | GA | d | | | | | | | |
| 80a-2 | 125 | 100 | 50 | 80 | 10 | 35 | 160 | 152 | 35.5 | 12 | 19j6 | 40 | 6h9 | 21.5 | M6 | 254 | 158 | 315 | 125 | 125 | 120 |

**The overall and mounting dimensions
IM 3001; IM 3011**

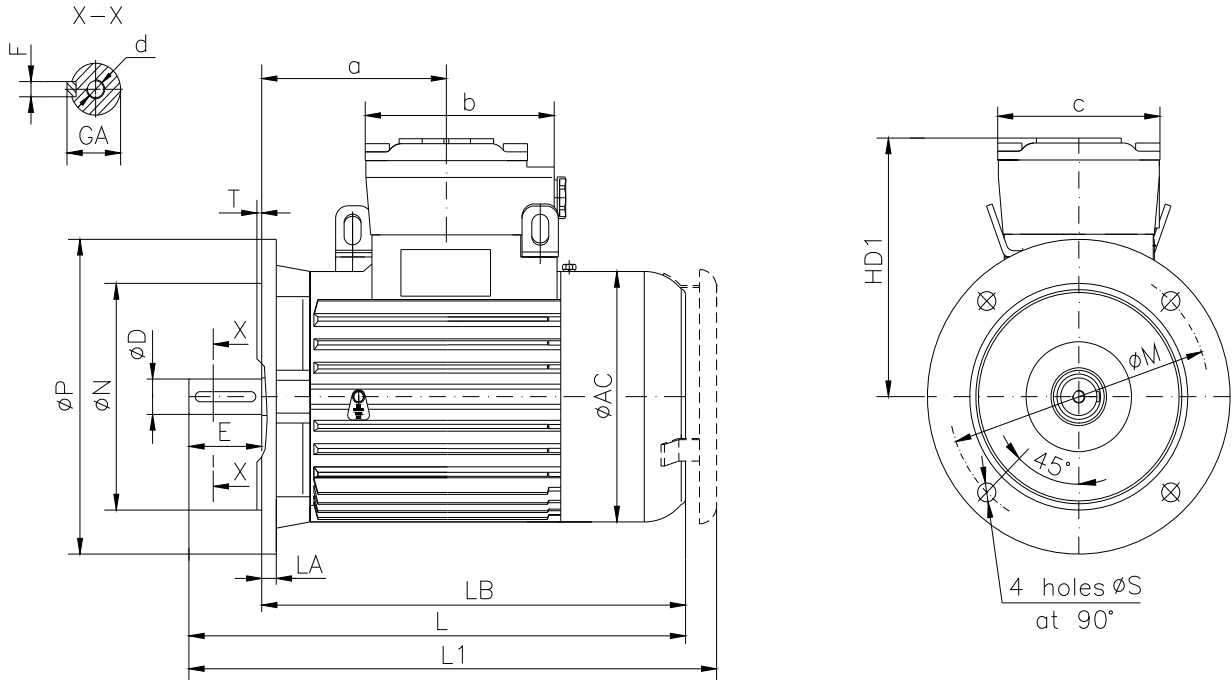

| Frame size | Dimensions (mm) | | | | | | | | | | | | | | | | | | |
|------------|----------------------|-----|-----|----|-----|-----------------|----|-----|------|----|-----|-----|----|-----|-----|-----|-----|-----|-----|
| | Flange mounting (B5) | | | | | Shaft extension | | | | | HD1 | AC | LA | LB | L | L1 | a | b | c |
| | N | M | P | S | T | D | E | F | GA | d | | | | | | | | | |
| 80a-2 | 130j6 | 165 | 200 | 12 | 3.5 | 19j6 | 40 | 6h9 | 21.5 | M6 | 174 | 158 | 10 | 275 | 315 | 346 | 125 | 125 | 120 |

**The overall and mounting dimensions
IM 3601**

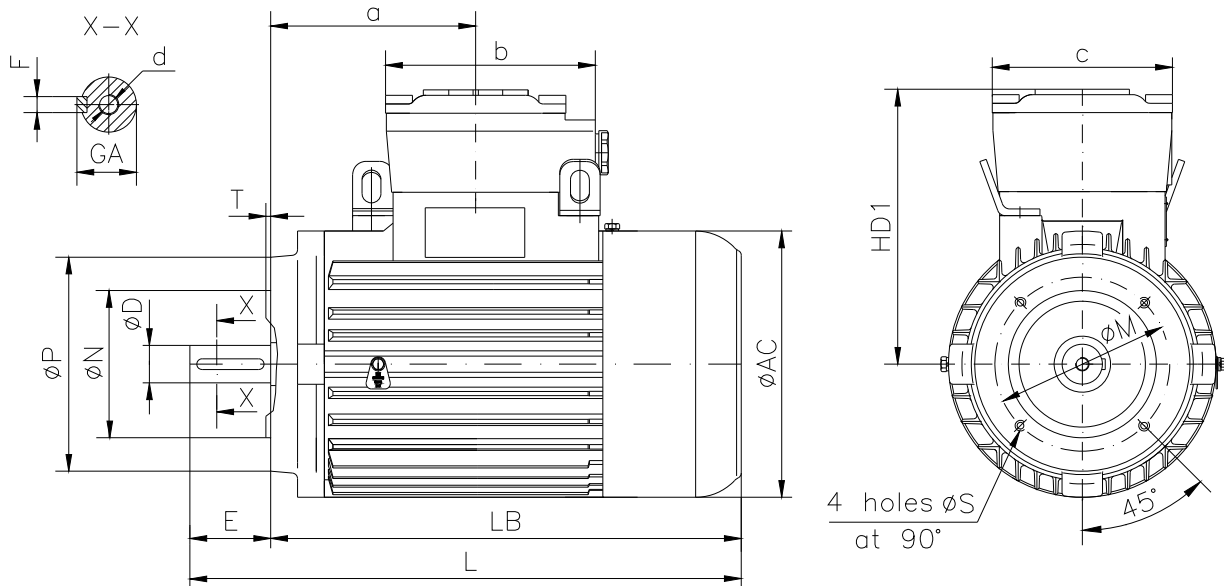

| Frame size | Dimensions (mm) | | | | | | | | | | | | | | | | | |
|------------|-----------------------|-------|-----|-----|----|-----|-----------------|----|-----|------|----|-----|-----|-----|-----|-----|-----|-----|
| | Flange mounting (B14) | | | | | | Shaft extension | | Fh9 | GA | d | AC | HD1 | LB | L | a | b | c |
| 80 a-2 | Flange | N | M | P | S | T | D | E | | | | | | | | | | |
| | F100 | 80j6 | 100 | 120 | M6 | 3 | 19j6 | 40 | 6 | 21.5 | M6 | 158 | 174 | 275 | 315 | 125 | 125 | 120 |
| | F130 | 110j6 | 130 | 160 | M8 | 3.5 | | | | | | | | | | | | |