

DATA SHEET

- Type.....E2-ASA 132Sa-2
- Reference standard..... IEC 60034-1; 60034-30
EN 60079-0
EN 60079-1
EN 60079-7
- Rated output..... 5.5 kW
- Rated stator voltage.....400V Y
- Stator current at 100% load.....10.1 [A]
- Number of poles.....2
- Rated speed.....2930 rev/min
- Rated frequency.....50Hz
- Efficiency at 100%, 75%, 50% load.....88.6%, 88.3%, 86.0%
- Power factor at 100% load.....0.85
- Break-down torque.....3.9 x Mn
- Locked rotor torque.....3.6 x Mn
- Locked rotor current.....7.7 x In
- Rotor inertia.....0.019133 kgm²
- Insulation class.....F
- Direction of rotation.....Both(CW&CCW)
- Protection degree.....≥IP55
- Mounting.....IM
- Cooling method.....IC 411
- Max. ambient temperature+ 40°C
- Altitude.....1000m
- Bearing type.....6308 2Z drive end
6308 2Z non drive end
- Weight.....97 Kg
- Outline drawing.....Page 2
- Vibration level :.....A (acc.IEC 60034-14)
- Noise levelacc.IEC 60034-9
- Cable entries.....2xM32x1.5
- Climate executionN

**The overall and mounting dimensions
IM 1001**

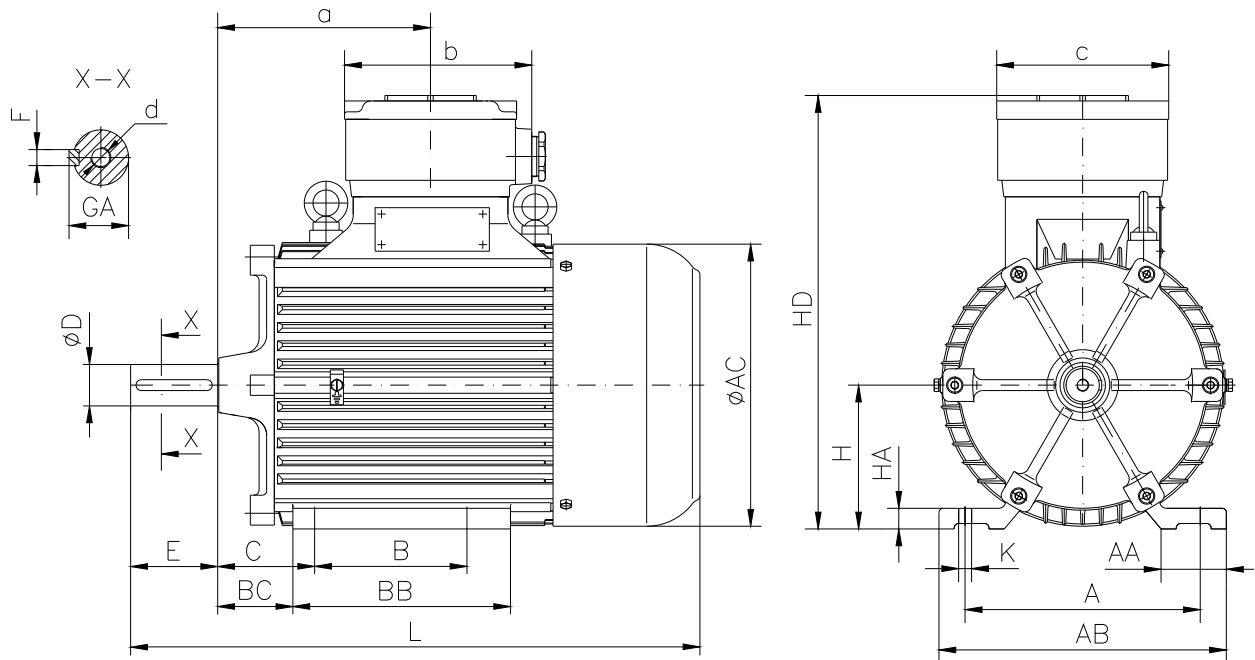

Frame size	Dimensions (mm)																				
	Foot mounting										Shaft extension						HD	AC	L	a	b
A	B	C	H _{0.5}	K	AA	AB	BB	BC	HA	D	E	F	GA	d							
132 Sa-2	216	140	89	132	12	60	264	200	69	19	38k6	80	10h9	41	M12	400	263	606	200	175	160

**The overall and mounting dimensions
IM 3001; IM 3011**

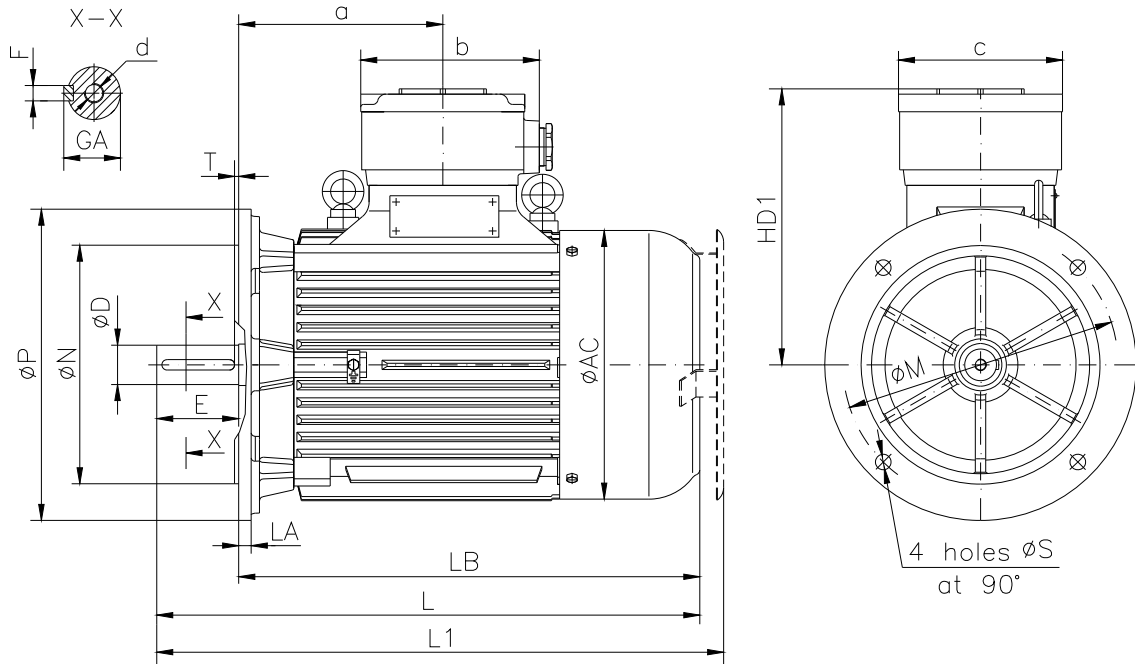

Frame size	Dimensions (mm)																		
	Flange mounting (B5)					Shaft extension					HD1	AC	LA	LB	L	L1	a	b	c
N	M	P	S	T	D	E	F	GA	d										
132 Sa-2	230j6	265	300	14.5	4	38k6	80	10h9	41	M12	268	263	12	526	606	644	200	175	160

**The overall and mounting dimensions
IM 3601**

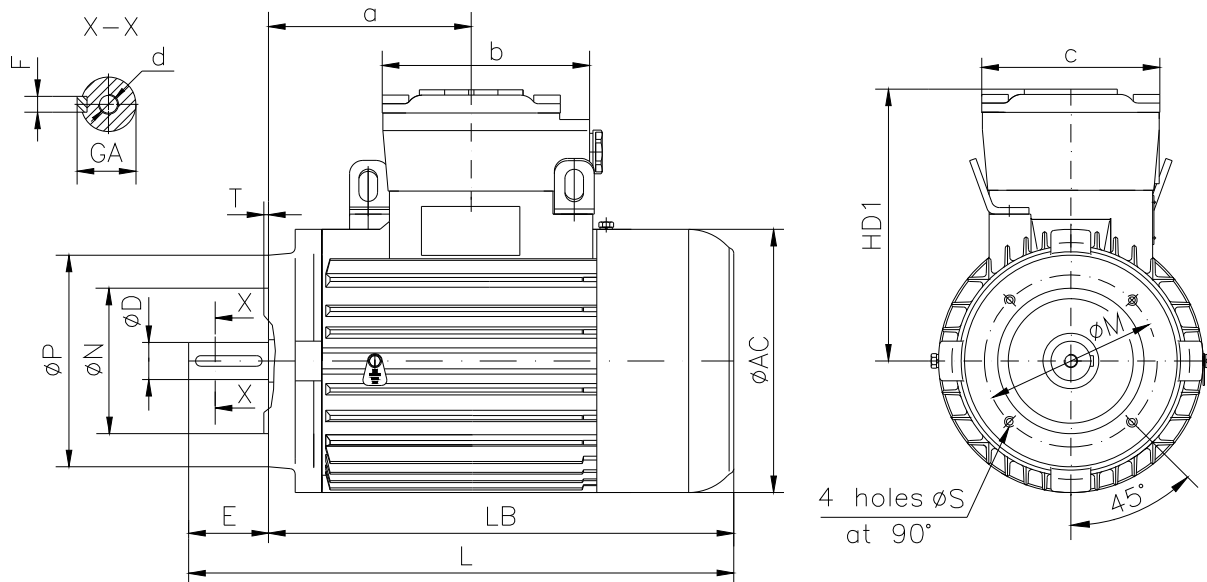

Frame size	Dimensions (mm)																	
	Flange mounting (B14)						Shaft extension		Fh9	GA	d	AC	HD1	LB	L	a	b	c
132 Sa-2	Flange	N	M	P	S	T	D	E										
	F165	130j6	165	200	M10	3.5	38k6	80	10	41	M12	263	268	526	606	200	175	160
	F215	180j6	215	250	M12	4												